

INSTALLATION INSTRUCTIONS

Fixed Cell Caps

1. Measure and cut hole in roof panel. (Width = I.D. x length = I.D.+ 8").
2. Mark curb flange locations on roof panel then remove curb and install 2 1/2" tape mastic 1/2" inside of mark.
3. Apply 1/4" bead of urethane caulk between tape mastic and mark at all 4 sides.
4. Place curb over opening and attach to roof with self-drill screws.
5. Finger tool all caulking to form caulking to provide proper seal and drainage.
6. Do not reverse steps 4 and 5.
7. Follow instructions on back of sheet for cell caps, screws, tape mastic, and caulk.

General Notes:

1. Cutting holes in roof panel should be done with an electric shear, nibbler, or reciprocating saw. The use of an abrasive saw will damage the finish of the roof panel.
2. Deburr all field cut edges at panel ribs. Cut (do not tear) tape mastic at 45° angle at corners.

Note: These instructions are meant as a general guide only. Some variations may occur, refer to as built drawings before proceeding.

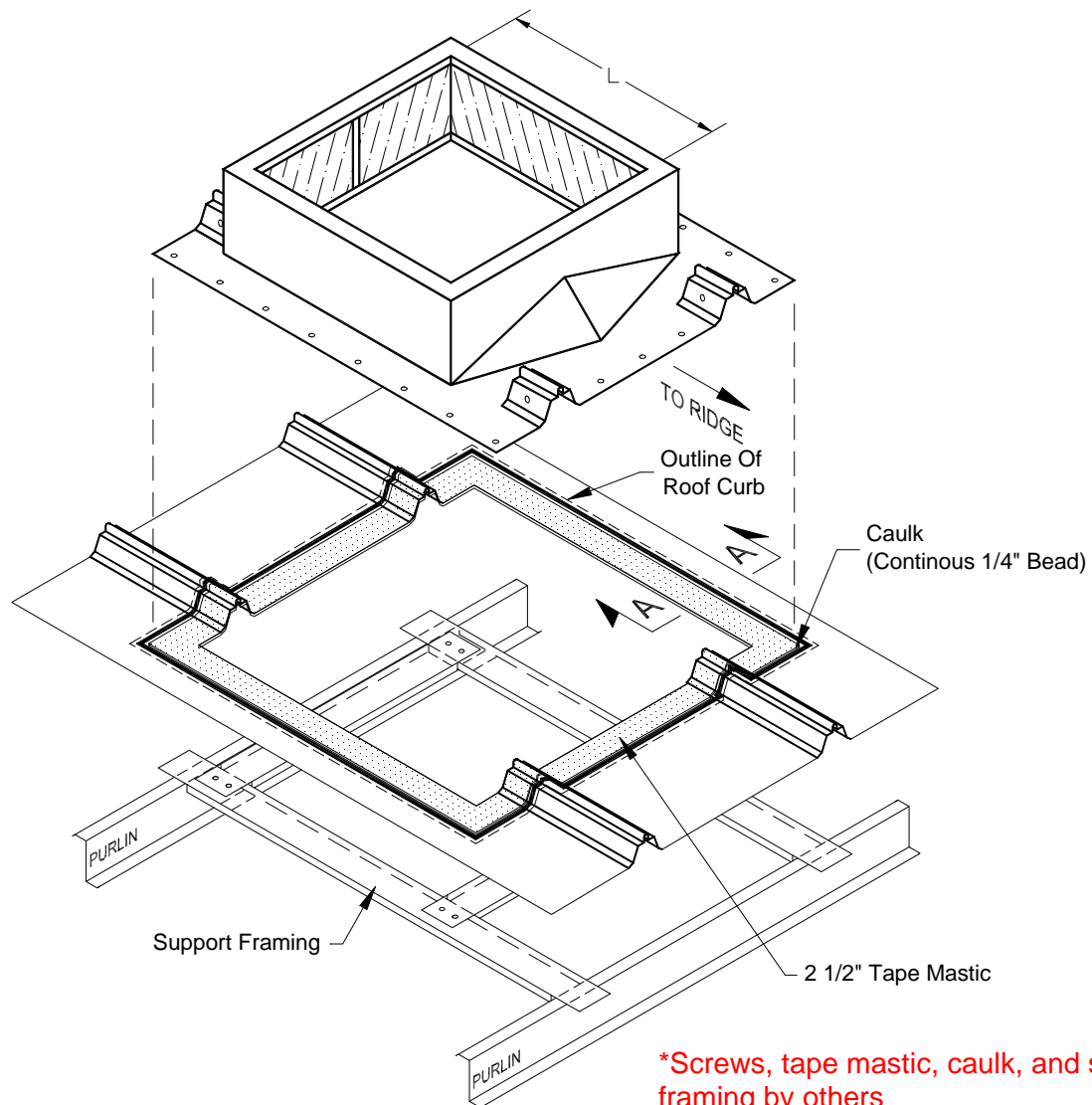

*Screws, tape mastic, caulk, and support framing by others

Standing Seam Roof Panel Erection Details-Fixed Cell Caps

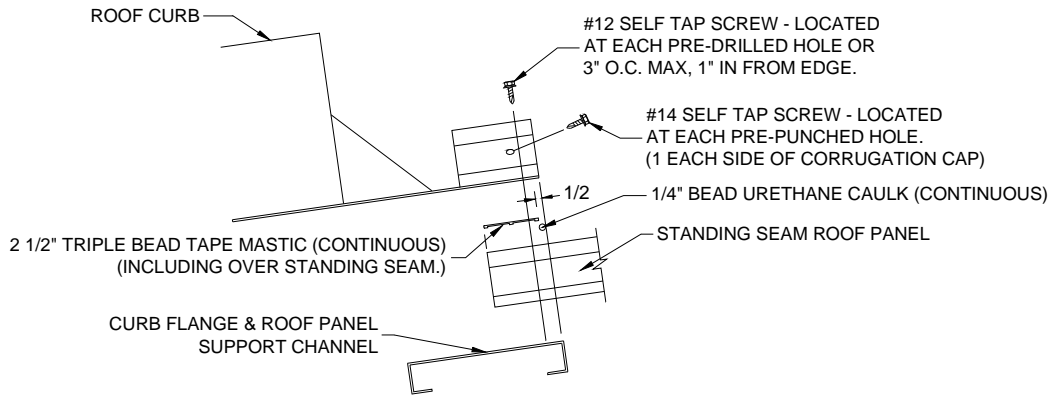

Roof Curb Upslope Flange

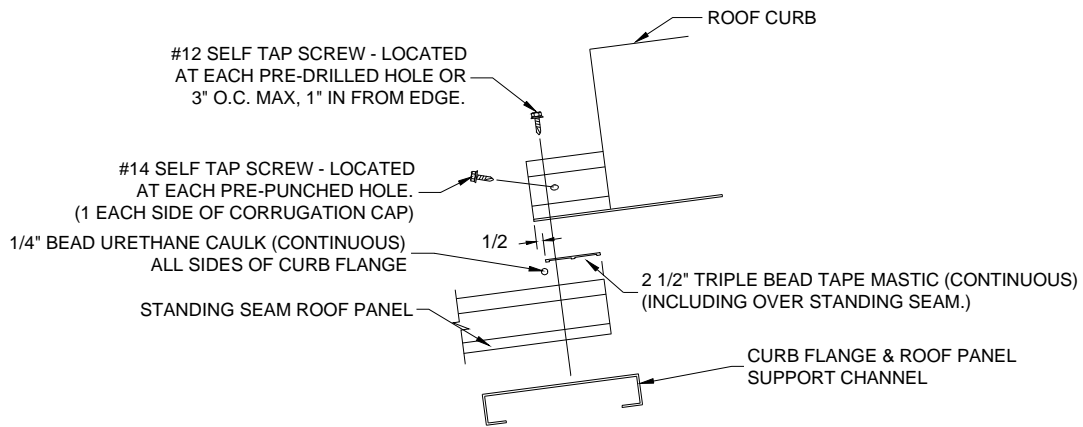

Roof Curb Downslope Flange

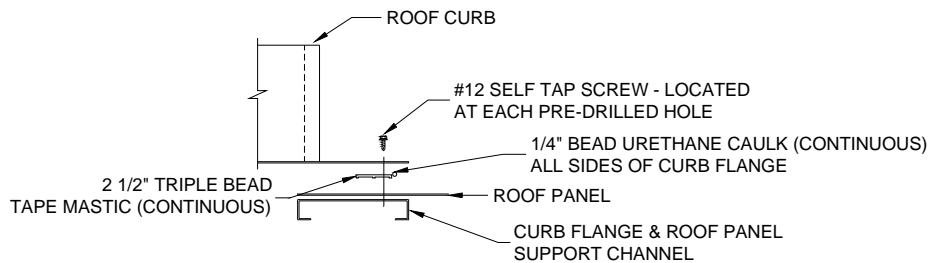

Roof Curb - Sides Section AA

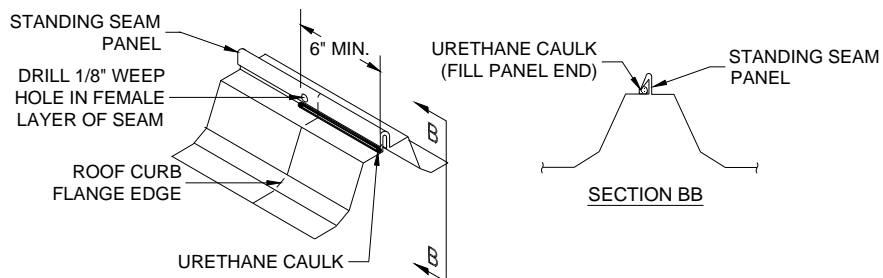

Treatment of Upslope Seams