

Thybar
Corporation

Pre-Fabricated Roof Curbs

Knock Down Curb Assembly Instructions



These roof curb assembly instructions are to be used as general guidelines only. Included with shipment are as-built drawings for proper location of sections and channels. Use as-built drawings to identify and locate match-marked sections (1-1, A-A, etc..)

If curbs will not be installed and roofed-in upon receipt, it is recommended that curbs should be stored level and adequately supported to avoid damage and, a clean, dry location to avoid possible corrosion problems associated with extended contact with the ground.

If the roof curb will be mounted on a **new building**, it can be assembled at any convenient location and installed as soon as the roof support members are in place. As a general rule, the curb should be placed directly on the roof support members, use tack welding (or other equivalent fastening method) to secure the curb in place.

As an alternative, the roof curb can also be mounted on a roof deck. When a deck is used, be sure to provide additional blocking directly below the curb flanges to give further support and minimize vibration.

When curb installation is on an **existing building**, hoist the curb shipping carton(s) directly to the roof. Curb assembly is more conveniently completed at this location.

Assembling Roof Curb

1. Select an area conveniently located near the unit installation site, and open the curb shipping carton(s). **Verify that all materials, nuts, bolts and gasketing, were received.**
2. Assemble curb quantity (2) side and end panels to form the 4-sided roof curb. Bolts required for curb assembly are shipped loose in the hardware carton, or are already bolted into the curb.

Note: Do not tighten any of the bolts used to assemble the curb until after the curb is installed, leveled and squared.

3. Install curb channel(s) to inside of roof curb by bolting channel-to-channel angle welded in place on curb wall. Refer to curb details for O.C. dimensions.
4. **Optional Plenum Assembly:** Install the return air floor panels, if shown on as built drawings, at the bottom of the curb. Lay the floor panels flat, standing seam up, on the existing roof decking. Floor panels **must be supported**. Caulk all seams and fasten with self-drilling sheet metal screws.
5. **Optional Pipe Chase:** Install pipe chase, if shown on as-built drawings. Locate pipe chase as per as-built curb drawing supplied with shipment. Screw to curb side wall through flange. Install gutter, if included between pipe chase and curb side wall. Caulk all seams as required.
6. Apply adhesive backed gasketing provided with curb to the entire perimeter of the top of roof curb and all supply & return channels.
7. **Optional TEMS Rail:** Locate TEMS Rail as per curb drawing supplied with shipment.

Recommended installation includes fastening base flange to roof steel or deck with stitch weld or mechanical fastener not exceeding 18" O.C. as per NRCA specifications.

Note: These instructions are meant as a general guide only. Some variations may occur, refer to as-built drawings before proceeding.

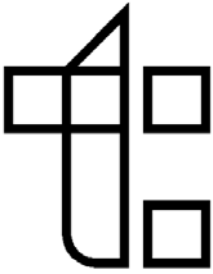

**Thybar
Corporation**

Pre-Fabricated Roof Curbs

Horizontal Assembly Instructions



These roof curb assembly instructions are to be used as general guidelines only. Included with shipment are as-built drawings for proper location of sections and channels. Use as-built drawings to identify and locate match marked sections (1-1, A-A, etc..)

If curbs will not be installed and roofed in upon receipt, it is recommended that curbs should be stored level and adequately supported to avoid damage and in a clean, dry location to avoid possible corrosion problems associated with extended contact with the ground.

If the roof curb will be mounted on a **new building**, it can be assembled at any convenient location and installed as soon as the roof support members are in place. As a general rule, the curb should be placed directly on the roof support members, use tack welding (or other equivalent fastening method) to secure the curb in place.

As an alternative, the roof curb can also be mounted on a roof deck. When a deck is used, be sure to provide additional blocking directly below the curb flanges to give further support and minimize vibration.

When curb installation is on an **existing building**, hoist the curb shipping carton(s) directly to the roof. Curb assembly is more conveniently completed at this location.

Assembling Horizontal Curbs

1. Select an area conveniently located near the unit installation site, and open the curb kit shipping
2. Carton(s). Verify that all materials, factory and field supplied, are on hand.
3. Arrange the curb rail sections
4. Assemble curb components (refer to Thybar provided as-built drawing) to form the supply side of the curb. Bolts required for curb assembly are shipped loose in the hardware carton or are already bolted into the curb.
Note: Do not tighten any of the bolts used to assemble the curb until after the curb is installed, leveled and squared.
5. Install the Thybar provided insulated supply floor panels at the bottom of the curb. Lay the floor panels flat; insulation side UP on the existing roof decking (refer to Thybar provided as-built drawing for quantity and mounting location). Make sure that the 1" flange on each floor panels is against the curb. Bolt, weld or button punch each floor panels into place, then caulk the outside edges of the floor panels with high-pressure duct sealer (field supplied). Floor panels must be supported.
6. Assemble curb components (refer to Thybar provided as-built drawing for quantity and mounting location) to form the return side of the curb. Then bolt the supply half to the return half. Verify that the curb is properly assembled by checking its overall dimensions against the appropriate curb assembly drawing. After curb is leveled and squared, all bolts may be tightened.

For Horizontal Supply & Return Curb

7. Install the return air floor panels at the bottom of the curb. Lay the floor panels flat with standing seam UP on the existing roof decking. Installation is similar to supply floor panel installation.

For Horizontal Supply & Vertical Return Curb

8. Install the return air filler panels at the bottom of the curb. Lay the filler panels flat, standing seam up, on the existing roof decking. Caulk all seams and fasten with Tek screws.
9. Apply adhesive backed gasketing provided with curb to the entire perimeter of the top of roof curb and all supply & return channels.

Recommended installation includes fastening base flange to roof steel or deck with stitch weld or mechanical fastener not exceeding 18" O.C. as per NRCA specifications.

Note: These instructions are meant as a general guide only. Some variations may occur, refer to as-built drawings before proceeding.

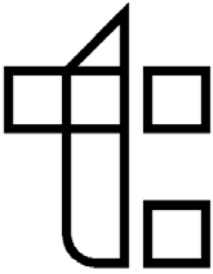

**Thybar
Corporation**

Extended (Full Perimeter) Roof Curb



Assembly Instructions

These roof curb assembly instructions are to be used as general guidelines only. Included with shipment are as-built drawings for proper location of sections and channels. Use as-built drawings to identify and locate match marked sections (1-1, A-A, etc..)

If curbs will not be installed and roofed in upon receipt, it is recommended that curbs should be stored level and adequately supported to avoid damage and, in a clean, dry location to avoid possible corrosion problems associated with extended contact with the ground.

If the roof curb will be mounted on a **new building**, it can be assembled at any convenient location and installed as soon as the roof support members are in place. As a general rule, the curb should be placed directly on the roof support members, use tack welding (or other equivalent fastening method) to secure the curb in place.

As an alternative, the roof curb can also be mounted on a roof deck. When a deck is used, be sure to provide additional blocking directly below the curb flanges to give further support and minimize vibration.

When curb installation is on an **existing building**, hoist the curb shipping carton(s) directly to the roof. Curb assembly is more conveniently completed at this location.

Assembling Roof Curb

1. Select an area conveniently located near the unit installation site and open the curb shipping carton(s). Verify that all materials, factory and field supplies are on hand.
2. Assemble curb components (refer to Thybar provided as-built drawing for quantity and mounting location) to form the supply side of the curb (return air supports are 1 1/4" down from the top of the roof curb and curb drain pan is flush with top of roof curb). Bolts required for curb assembly are provided loose in the hardware carton or are already bolted into the curb.

Note: Do not tighten any of the bolts used to assemble the curb until after the curb is installed, leveled and squared.

3. Condenser Drain Pan Assembly (See condenser drain pan detail):

1. Place support channels on tabs to support pans.

Standing Seam Type

2. Set first pan with male lock on the condenser end of curb and the support channel.
3. Fill female side of seam with caulk and install over male seam.
4. Button punch standing seams every 8" o.c., or Tek screw together.
5. Repeat these steps as necessary for additional pans.

4. Shingle Type

1. Remove protective backing from 2 1/2" mastic tape at condenser end.
2. Begin with panel #1 and lay panels in place ending with panel #3. Do not secure until all panels are in place and in the right locations.
3. Secure all panels around perimeter and across midsections with self-drilling rubber washer screws 3" o.c. and use Tek screws.)
4. Caulk all corners and seams with urethane caulk.

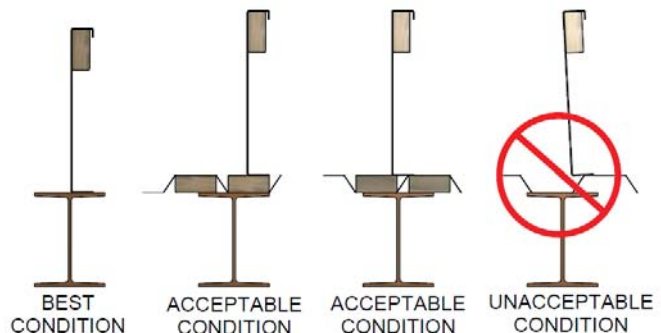

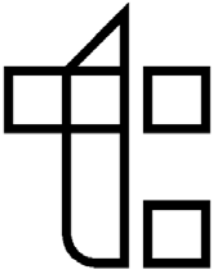

Thybar Corporation

Pre-Fabricated Roof Curbs

Horizontal Assembly Instructions



KNOCK DOWN INSULATED PLENUM CURB

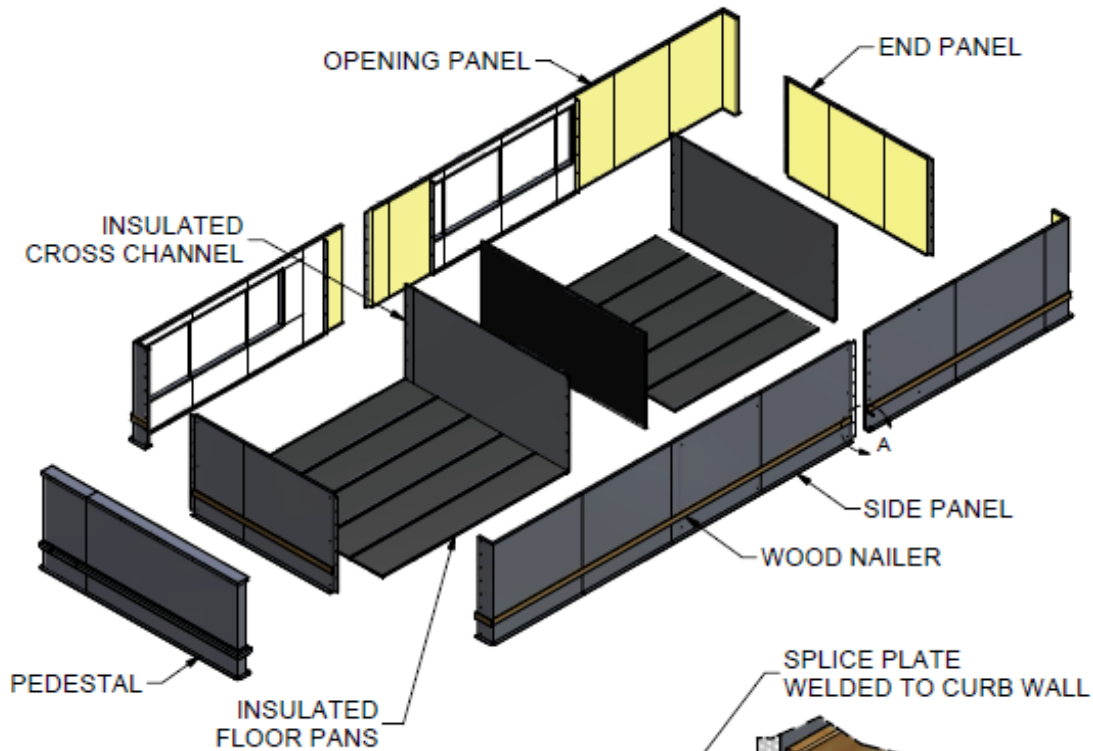

Align curb walls using alignment designators, bolt together with supplied hardware.

Contractor to caulk, seal and seam tape all plenum areas and floor pans after assembly, to ensure an air tight seal.

Curb flashing is shipped loose for field install after roof in.

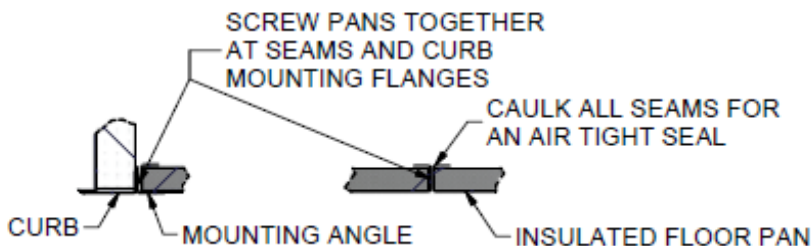
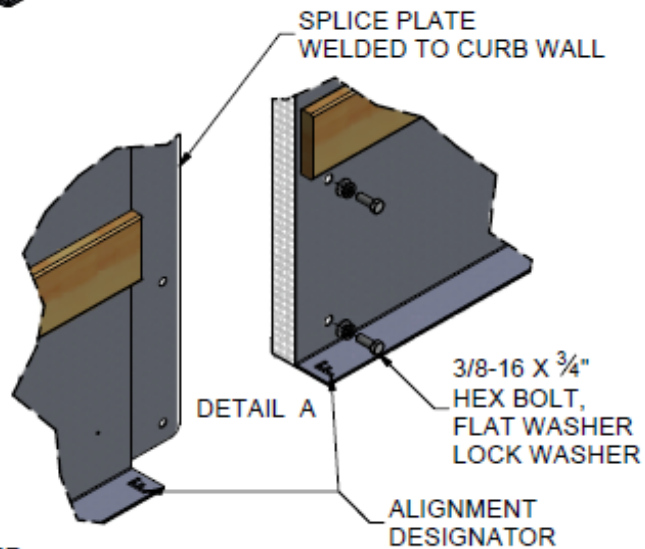

NOTE: Floor Pans cannot hold additional weight without being supported by decking or structure.

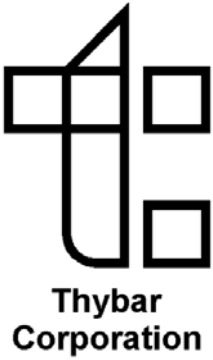

MULTIPLE SECTION KNOCK DOWN DRAIN PAN ASSEMBLY

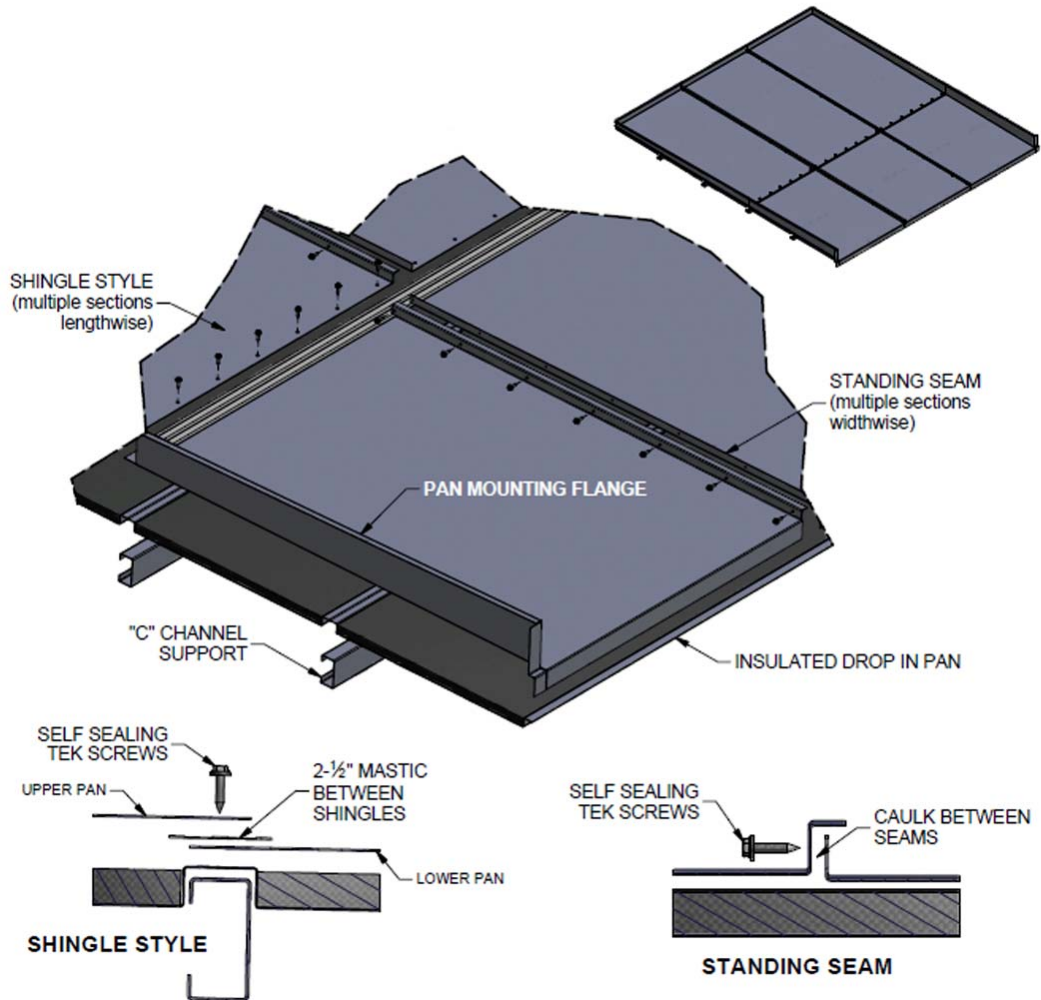

PLACE SUPPORT CHANNELS IN CURB, (ref: specific curb knock down assembly instruction for location and mounting). INSTALL ALL INSULATED DROP PANS (if provide) PRIOR TO DRAIN PAN ASSEMBLY.

FOR STANDING SEAM STYLE PAN SECTIONS: RUN A 1/4" BEAD OF URETHANE CAULK ALONG THE SEAM RAIL, (between the seam), AND BENEATHE THE PAN MOUNTING FLANGE. PLACE PANELS ON CURB CHANNEL WITH SEAMS MATED TO ONE ANOTHER. SCREW PANELS TOGETHER WITH SELF SEALING TEK SCREWS AT EACH HOLE LOCATION AND THROUGH MOUNTING FLANGE TO CURB CHANNEL.

FOR SHINGLE STYLE PAN SECTIONS: RUN A 1/4" BEAD OF URETHANE CAULK BENEATH THE PAN MOUNTING FLANGE ON ALL SECTIONS. PLACE LOWER PAN SECTION ON CURB CHANNEL, APPLY MASTIC TAOE AND LOWER PAN FLANGE, (ensure pan side rails are mated). SCREW DOWN THROUGH UPPER PAN. MASTIC AND LOWER PAN FLANGE INTO "C" CHANNEL, AND ALONG MOUNTING FLANGE INTO CURB CHANNEL.

REPEAT AS REQUIRED FOR ALL SECTIONS, FULLY CAULK ALL SEAMS AND CORNERS WITH URETHANE CAULK AFTER ASSEMBLY

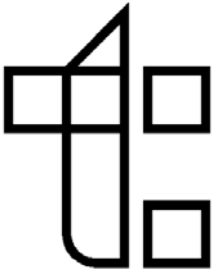

Thybar Corporation

Pre-Fabricated Roof Curbs

TC-3 Installation Detail

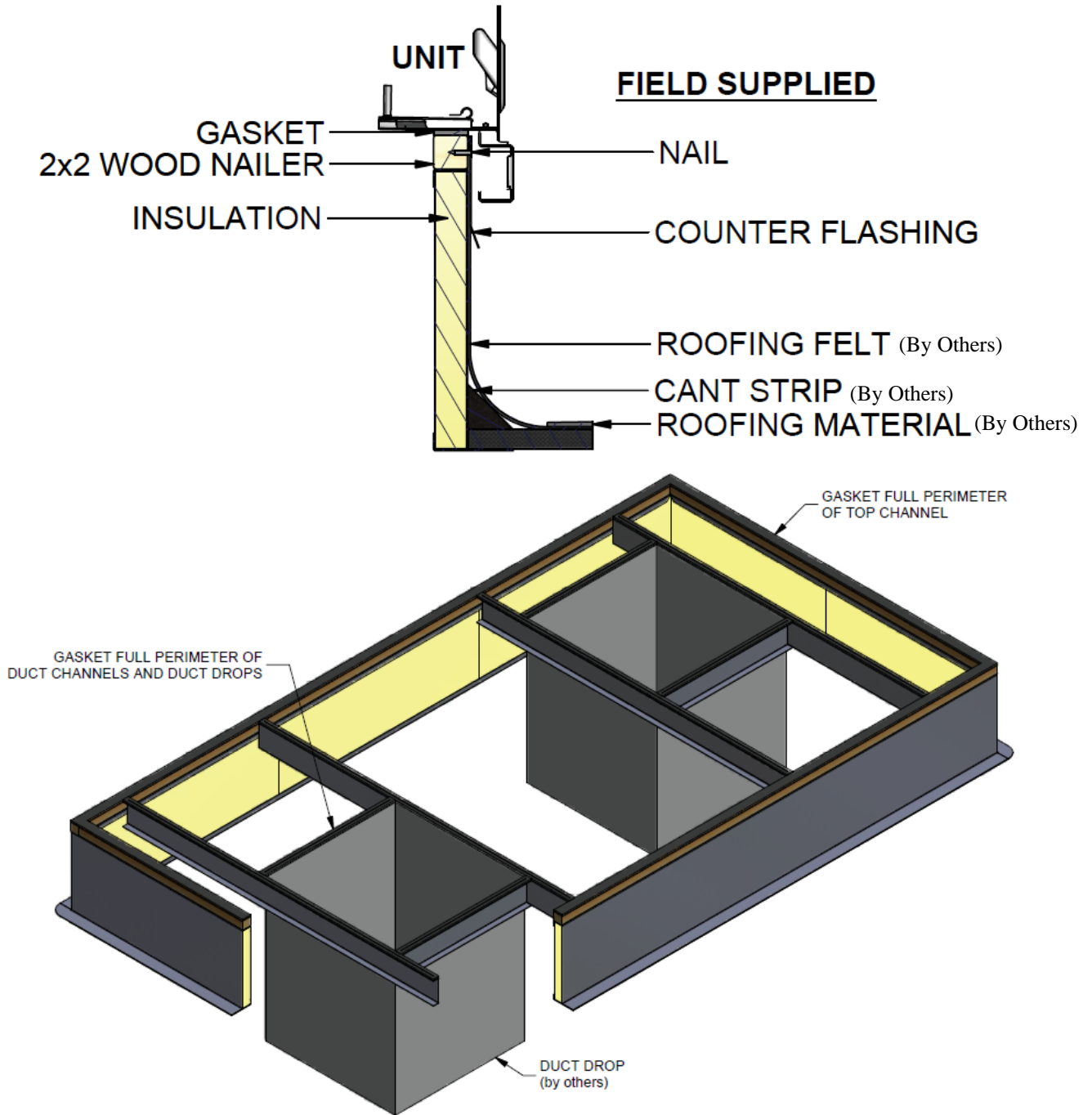

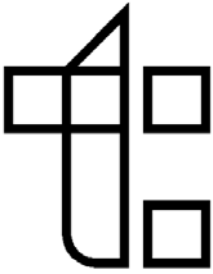

Thybar Corporation

Pre-Fabricated Roof Curbs

TC-5 Installation Detail

