

Equipment Mounting Supports

Thybar Equipment Mounting Supports are factory fabricated sheet steel structural members designed for placement on all types of roof systems and at the same time accommodates a variety of roof mounted heating, ventilating and air conditioning equipment. These units have a high load-bearing capacity attained by a system of internal bulkheads welded into position at specific intervals along the length of the rails.

A continuous wood nailer covered by a removable counterflashing provides for an effective method of attaching roofing felts and assuring a watertight installation.

Equipment Supports are fabricated in three basic styles designed for the following applications:

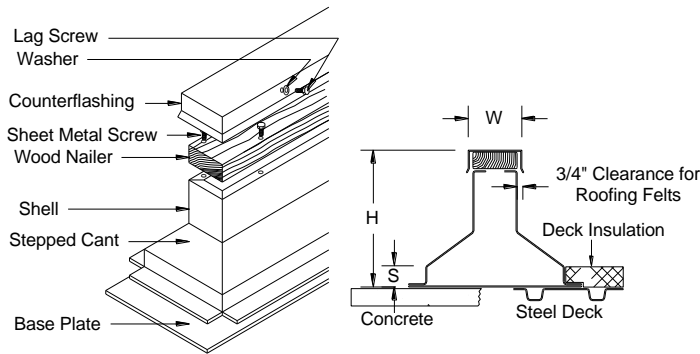

TEMS-1

For insulated Roof Decks with 3" cant and variable step to match deck insulation thickness.

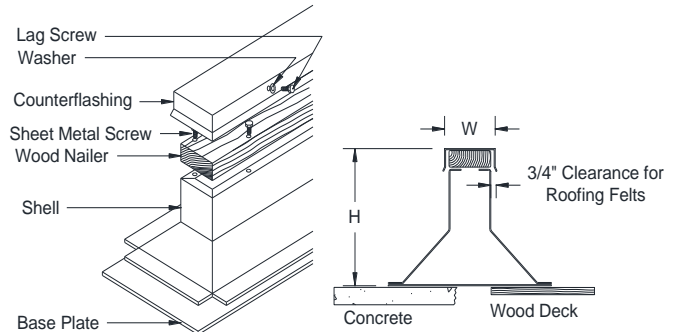

TEMS-2

For Non-Insulated Roof Decks with 3" cant.

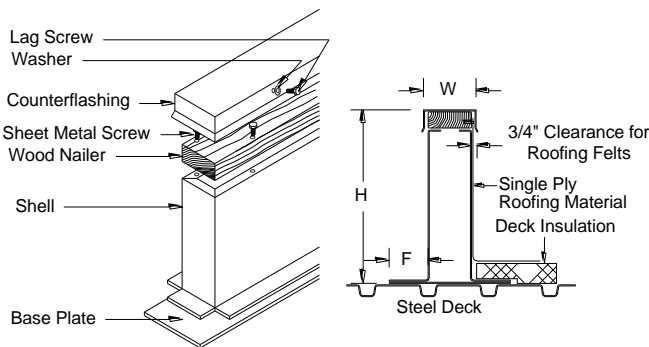

TEMS-3

For All Types of Roof Decks

Standard Construction:

1. 18 Ga. Galvanized steel shell, base plate and counterflashing
2. Factory installed wood nailer
3. Internal bulkhead reinforcement
4. All welded construction

Added Options:

- 5.
- 6.
- 7.
- 8.
- 9.

Qty	Style	Length	H	W	F	S	Pitch per Foot	Options	Tag

Equipment Mounting Supports Load Bearing Data

18 Gauge						
	TEMS-1		TEMS-2		TEMS-3	
Nailer Height	2x4 10"	2x6 14"	2x4 8"	2x6 12"	2x4 12"	2x6 16"
Area IN ²	1.68	2.18	1.39	1.96	1.45	1.95
S IN ³	2.64	3.1	1.46	2.46	3.09	3.81
I IN ⁴	17.8	10.23	6.37	23.22	21.74	42.37
Load/Ft.	730	850	400	580	850	1100
Center Load*	1900	2000	1400	1800	2200	2600
End Reaction	2300	3000	2200	3500	3000	3200
Intermediate Reaction	1900	2000	1500	1900	2200	2400
14 Gauge						
	TEMS-1		TEMS-2		TEMS-3	
Nailer Height	2x4 10"	2x6 14"	2x4 8"	2x6 12"	2x4 12"	2x6 16"
Area IN ²	2.52	3.27	2.16	3.06	2.17	2.92
S IN ³	3.95	7.29	2.27	5.17	4.63	6.43
I IN ⁴	26.7	61.9	9.9	40.62	32.6	65.5
Load/Ft.	1100	1500	630	1430	1280	1780
Center Load*	4300	4900	2300	4400	3700	4400
End Reaction	4500	6000	4300	6000	4200	6000
Intermediate Reaction	4000	4500	2500	3600	4300	4400

* 8' Span

Data was obtained from standard production samples and contains a safety factor of 2. Thybar Corporation can certify load conditions not covered above upon request.

All concentrated loads are based on a minimum bearing surface width of 4" by the full width of the supports. A minimum spacing of two feet will be required between combination loads, which exceed the recommended maximum values. No load should be applied on cantilever section in excess of 6 inches in length.